

Generators selected (1); $t(1,0,0)$; $t(0,1,0)$; $t(0,0,1)$; $t(\frac{1}{2}, \frac{1}{2}, \frac{1}{2})$; (2); (3); (5); (9)

Positions

Multiplicity,
Wyckoff letter,
Site symmetry

Coordinates

$(0,0,0) + (\frac{1}{2}, \frac{1}{2}, \frac{1}{2}) +$

Reflection conditions

General:

32	<i>i</i> 1	(1) x, y, z (5) $\bar{x} + \frac{1}{2}, y, \bar{z} + \frac{3}{4}$ (9) $\bar{x}, \bar{y} + \frac{1}{2}, \bar{z} + \frac{1}{4}$ (13) $x + \frac{1}{2}, \bar{y} + \frac{1}{2}, z + \frac{1}{2}$	(2) $\bar{x} + \frac{1}{2}, \bar{y} + \frac{1}{2}, z + \frac{1}{2}$ (6) $x, \bar{y} + \frac{1}{2}, \bar{z} + \frac{1}{4}$ (10) $x + \frac{1}{2}, y, \bar{z} + \frac{3}{4}$ (14) \bar{x}, y, z	(3) $\bar{y}, x + \frac{1}{2}, z + \frac{1}{4}$ (7) $y + \frac{1}{2}, x + \frac{1}{2}, \bar{z} + \frac{1}{2}$ (11) y, \bar{x}, \bar{z} (15) $\bar{y} + \frac{1}{2}, \bar{x}, z + \frac{3}{4}$	(4) $y + \frac{1}{2}, \bar{x}, z + \frac{3}{4}$ (8) $\bar{y}, \bar{x}, \bar{z}$ (12) $\bar{y} + \frac{1}{2}, x + \frac{1}{2}, \bar{z} + \frac{1}{2}$ (16) $y, x + \frac{1}{2}, z + \frac{1}{4}$	<p>$hkl: h + k + l = 2n$ $hk0: h, k = 2n$ $0kl: k + l = 2n$ $hhl: 2h + l = 4n$ $00l: l = 4n$ $h00: h = 2n$ $h\bar{h}0: h = 2n$</p>
16	<i>h</i> . <i>m</i> .	$0, y, z$ $\frac{1}{2}, y, \bar{z} + \frac{3}{4}$	$\frac{1}{2}, \bar{y} + \frac{1}{2}, z + \frac{1}{2}$ $0, \bar{y} + \frac{1}{2}, \bar{z} + \frac{1}{4}$	$\bar{y}, \frac{1}{2}, z + \frac{1}{4}$ $y + \frac{1}{2}, \frac{1}{2}, \bar{z} + \frac{1}{2}$	$y + \frac{1}{2}, 0, z + \frac{3}{4}$ $\bar{y}, 0, \bar{z}$	<p>Special: as above, plus no extra conditions</p>
16	<i>g</i> . . 2	$x, x, 0$ $\bar{x}, \bar{x} + \frac{1}{2}, \frac{1}{4}$	$\bar{x} + \frac{1}{2}, \bar{x} + \frac{1}{2}, \frac{1}{2}$ $x + \frac{1}{2}, x, \frac{3}{4}$	$\bar{x}, x + \frac{1}{2}, \frac{1}{4}$ $x, \bar{x}, 0$	$x + \frac{1}{2}, \bar{x}, \frac{3}{4}$ $\bar{x} + \frac{1}{2}, x + \frac{1}{2}, \frac{1}{2}$	<p>$hkl: l = 2n + 1$ or $2h + l = 4n$</p>
16	<i>f</i> . 2 .	$x, \frac{1}{4}, \frac{1}{8}$ $\bar{x}, \frac{1}{4}, \frac{1}{8}$	$\bar{x} + \frac{1}{2}, \frac{1}{4}, \frac{5}{8}$ $x + \frac{1}{2}, \frac{1}{4}, \frac{5}{8}$	$\frac{3}{4}, x + \frac{1}{2}, \frac{3}{8}$ $\frac{1}{4}, \bar{x}, \frac{7}{8}$	$\frac{3}{4}, \bar{x}, \frac{7}{8}$ $\frac{1}{4}, x + \frac{1}{2}, \frac{3}{8}$	<p>$hkl: l = 2n + 1$ or $h = 2n$</p>
8	<i>e</i> 2 <i>m m</i> .	$0, 0, z$	$0, \frac{1}{2}, z + \frac{1}{4}$	$\frac{1}{2}, 0, \bar{z} + \frac{3}{4}$	$\frac{1}{2}, \frac{1}{2}, \bar{z} + \frac{1}{2}$	<p>$hkl: l = 2n + 1$ or $2h + l = 4n$</p>
8	<i>d</i> . 2/ <i>m</i> .	$0, \frac{1}{4}, \frac{5}{8}$	$\frac{1}{2}, \frac{1}{4}, \frac{1}{8}$	$\frac{3}{4}, \frac{1}{2}, \frac{7}{8}$	$\frac{3}{4}, 0, \frac{3}{8}$	<p>$hkl: l = 2n + 1$ or $h, k = 2n, h + k + l = 4n$</p>
8	<i>c</i> . 2/ <i>m</i> .	$0, \frac{1}{4}, \frac{1}{8}$	$\frac{1}{2}, \frac{1}{4}, \frac{5}{8}$	$\frac{3}{4}, \frac{1}{2}, \frac{3}{8}$	$\frac{3}{4}, 0, \frac{7}{8}$	
4	<i>b</i> $\bar{4}m2$	$0, 0, \frac{1}{2}$	$0, \frac{1}{2}, \frac{3}{4}$	<p>$hkl: l = 2n + 1$ or $2h + l = 4n$</p>		
4	<i>a</i> $\bar{4}m2$	$0, 0, 0$	$0, \frac{1}{2}, \frac{1}{4}$			

Symmetry of special projections

Along [001] $p4mm$
 $\mathbf{a}' = \frac{1}{2}\mathbf{a}$ $\mathbf{b}' = \frac{1}{2}\mathbf{b}$
Origin at 0, 0, z

Along [100] $c2mm$
 $\mathbf{a}' = \mathbf{b}$ $\mathbf{b}' = \mathbf{c}$
Origin at $x, 0, \frac{3}{8}$

Along [110] $c2mm$
 $\mathbf{a}' = \frac{1}{2}(-\mathbf{a} + \mathbf{b})$ $\mathbf{b}' = \frac{1}{2}\mathbf{c}$
Origin at $x, x, 0$

$I4_1/amd$ D_{4h}^{19} $4/mmm$

Tetragonal

No. 141

 $I 4_1/a 2/m 2/d$ Patterson symmetry $I4/mmm$

ORIGIN CHOICE 2

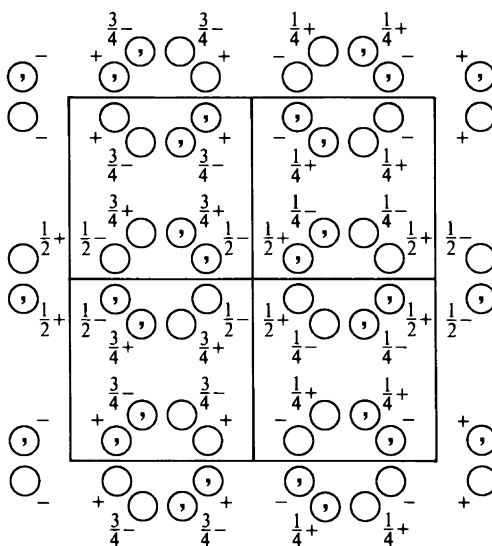
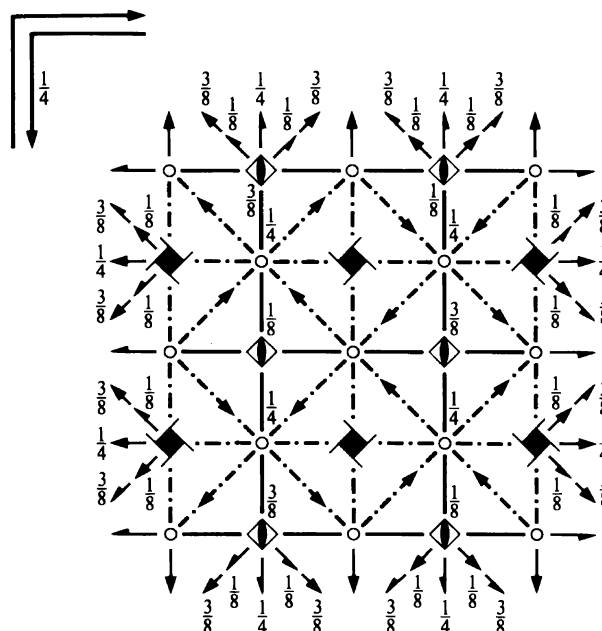

Origin at centre ($2/m$) at $b(2/m, 2_1/n)d$, at $0, -\frac{1}{4}, \frac{1}{8}$ from $\bar{4}m2$

Asymmetric unit $0 \leq x \leq \frac{1}{2}; -\frac{1}{4} \leq y \leq \frac{1}{4}; 0 \leq z \leq \frac{1}{8}$

Symmetry operations

For $(0, 0, 0)+$ set

- | | | | |
|---|--|---|---|
| (1) 1 | (2) $2(0, 0, \frac{1}{2})$ $\frac{1}{4}, 0, z$ | (3) $4^+(0, 0, \frac{1}{4})$ $-\frac{1}{4}, \frac{1}{2}, z$ | (4) $4^-(0, 0, \frac{3}{4})$ $\frac{1}{4}, 0, z$ |
| (5) 2 $\frac{1}{4}, y, \frac{1}{4}$ | (6) 2 $x, 0, 0$ | (7) $2(\frac{1}{2}, \frac{1}{2}, 0)$ $x, x + \frac{1}{4}, \frac{1}{8}$ | (8) 2 $x, \bar{x} + \frac{1}{4}, \frac{3}{8}$ |
| (9) $\bar{1}$ $0, 0, 0$ | (10) a $x, y, \frac{1}{4}$ | (11) 4^+ $\frac{1}{2}, -\frac{1}{4}, z;$ $\frac{1}{2}, -\frac{1}{4}, \frac{3}{8}$ | (12) 4^- $0, \frac{3}{4}, z;$ $0, \frac{3}{4}, \frac{1}{8}$ |
| (13) $n(\frac{1}{2}, 0, \frac{1}{2})$ $x, 0, z$ | (14) m $0, y, z$ | (15) $d(\frac{1}{4}, -\frac{1}{4}, \frac{3}{4})$ $x + \frac{1}{2}, \bar{x}, z$ | (16) $d(\frac{3}{4}, \frac{3}{4}, \frac{1}{4})$ x, x, z |

For $(\frac{1}{2}, \frac{1}{2}, \frac{1}{2})+$ set

- | | | | |
|---|---|---|---|
| (1) $t(\frac{1}{2}, \frac{1}{2}, \frac{1}{2})$ | (2) 2 $0, \frac{1}{4}, z$ | (3) $4^+(0, 0, \frac{3}{4})$ $\frac{1}{4}, \frac{1}{2}, z$ | (4) $4^-(0, 0, \frac{1}{4})$ $\frac{3}{4}, 0, z$ |
| (5) $2(0, \frac{1}{2}, 0)$ $0, y, 0$ | (6) $2(\frac{1}{2}, 0, 0)$ $x, \frac{1}{4}, \frac{1}{4}$ | (7) $2(\frac{1}{2}, \frac{1}{2}, 0)$ $x, x - \frac{1}{4}, \frac{3}{8}$ | (8) 2 $x, \bar{x} + \frac{3}{4}, \frac{1}{8}$ |
| (9) $\bar{1}$ $\frac{1}{4}, \frac{1}{4}, \frac{1}{4}$ | (10) b $x, y, 0$ | (11) 4^+ $\frac{1}{2}, \frac{1}{4}, z;$ $\frac{1}{2}, \frac{1}{4}, \frac{1}{8}$ | (12) 4^- $0, \frac{1}{4}, z;$ $0, \frac{1}{4}, \frac{3}{8}$ |
| (13) m $x, \frac{1}{4}, z$ | (14) $n(0, \frac{1}{2}, \frac{1}{2})$ $\frac{1}{4}, y, z$ | (15) $d(-\frac{1}{4}, \frac{1}{4}, \frac{1}{4})$ $x + \frac{1}{2}, \bar{x}, z$ | (16) $d(\frac{1}{4}, \frac{1}{4}, \frac{3}{4})$ x, x, z |

Generators selected (1); $t(1,0,0)$; $t(0,1,0)$; $t(0,0,1)$; $t(\frac{1}{2}, \frac{1}{2}, \frac{1}{2})$; (2); (3); (5); (9)

Positions

Multiplicity, Wyckoff letter, Site symmetry	Coordinates $(0,0,0) + (\frac{1}{2}, \frac{1}{2}, \frac{1}{2}) +$				Reflection conditions
32 <i>i</i> 1	(1) x, y, z (5) $\bar{x} + \frac{1}{2}, y, \bar{z} + \frac{1}{2}$ (9) $\bar{x}, \bar{y}, \bar{z}$ (13) $x + \frac{1}{2}, \bar{y}, z + \frac{1}{2}$	(2) $\bar{x} + \frac{1}{2}, \bar{y}, z + \frac{1}{2}$ (6) x, \bar{y}, \bar{z} (10) $x + \frac{1}{2}, y, \bar{z} + \frac{1}{2}$ (14) \bar{x}, y, z	(3) $\bar{y} + \frac{1}{4}, x + \frac{3}{4}, z + \frac{1}{4}$ (7) $y + \frac{1}{4}, x + \frac{3}{4}, \bar{z} + \frac{1}{4}$ (11) $y + \frac{3}{4}, \bar{x} + \frac{1}{4}, \bar{z} + \frac{3}{4}$ (15) $\bar{y} + \frac{3}{4}, \bar{x} + \frac{1}{4}, z + \frac{3}{4}$	(4) $y + \frac{1}{4}, \bar{x} + \frac{1}{4}, z + \frac{3}{4}$ (8) $\bar{y} + \frac{1}{4}, \bar{x} + \frac{1}{4}, \bar{z} + \frac{3}{4}$ (12) $\bar{y} + \frac{3}{4}, x + \frac{3}{4}, \bar{z} + \frac{1}{4}$ (16) $y + \frac{3}{4}, x + \frac{3}{4}, z + \frac{1}{4}$	General: $hkl: h + k + l = 2n$ $hk0: h, k = 2n$ $0kl: k + l = 2n$ $hhl: 2h + l = 4n$ $00l: l = 4n$ $h00: h = 2n$ $h\bar{h}0: h = 2n$ Special: as above, plus no extra conditions
16 <i>h</i> . <i>m</i> .	$0, y, z$ $\frac{1}{2}, y, \bar{z} + \frac{1}{2}$	$\frac{1}{2}, \bar{y}, z + \frac{1}{2}$ $0, \bar{y}, \bar{z}$	$\bar{y} + \frac{1}{4}, \frac{3}{4}, z + \frac{1}{4}$ $y + \frac{1}{4}, \frac{3}{4}, \bar{z} + \frac{1}{4}$	$y + \frac{1}{4}, \frac{1}{4}, z + \frac{3}{4}$ $\bar{y} + \frac{1}{4}, \frac{1}{4}, \bar{z} + \frac{3}{4}$	
16 <i>g</i> . . 2	$x, x + \frac{1}{4}, \frac{7}{8}$ $\bar{x}, \bar{x} + \frac{3}{4}, \frac{1}{8}$	$\bar{x} + \frac{1}{2}, \bar{x} + \frac{3}{4}, \frac{3}{8}$ $x + \frac{1}{2}, x + \frac{1}{4}, \frac{5}{8}$	$\bar{x}, x + \frac{3}{4}, \frac{1}{8}$ $x, \bar{x} + \frac{1}{4}, \frac{7}{8}$	$x + \frac{1}{2}, \bar{x} + \frac{1}{4}, \frac{5}{8}$ $\bar{x} + \frac{1}{2}, x + \frac{3}{4}, \frac{3}{8}$	$hkl: l = 2n + 1$ or $2h + l = 4n$
16 <i>f</i> . 2 .	$x, 0, 0$ $\bar{x}, 0, 0$	$\bar{x} + \frac{1}{2}, 0, \frac{1}{2}$ $x + \frac{1}{2}, 0, \frac{1}{2}$	$\frac{1}{4}, x + \frac{3}{4}, \frac{1}{4}$ $\frac{3}{4}, \bar{x} + \frac{1}{4}, \frac{3}{4}$	$\frac{1}{4}, \bar{x} + \frac{1}{4}, \frac{3}{4}$ $\frac{3}{4}, x + \frac{3}{4}, \frac{1}{4}$	$hkl: l = 2n + 1$ or $h = 2n$
8 <i>e</i> 2 <i>m m</i> .	$0, \frac{1}{4}, z$	$0, \frac{3}{4}, z + \frac{1}{4}$	$\frac{1}{2}, \frac{1}{4}, \bar{z} + \frac{1}{2}$	$\frac{1}{2}, \frac{3}{4}, \bar{z} + \frac{1}{4}$	$hkl: l = 2n + 1$ or $2h + l = 4n$
8 <i>d</i> . 2/ <i>m</i> .	$0, 0, \frac{1}{2}$	$\frac{1}{2}, 0, 0$	$\frac{1}{4}, \frac{3}{4}, \frac{3}{4}$	$\frac{1}{4}, \frac{1}{4}, \frac{1}{4}$	$hkl: l = 2n + 1$ or $h, k = 2n, h + k + l = 4n$
8 <i>c</i> . 2/ <i>m</i> .	$0, 0, 0$	$\frac{1}{2}, 0, \frac{1}{2}$	$\frac{1}{4}, \frac{3}{4}, \frac{1}{4}$	$\frac{1}{4}, \frac{1}{4}, \frac{3}{4}$	
4 <i>b</i> $\bar{4}m2$	$0, \frac{1}{4}, \frac{3}{8}$	$0, \frac{3}{4}, \frac{5}{8}$	$\frac{1}{2}, \frac{3}{4}, \frac{3}{8}$	$\frac{1}{2}, \frac{3}{4}, \frac{1}{8}$	$hkl: l = 2n + 1$ or $2h + l = 4n$
4 <i>a</i> $\bar{4}m2$	$0, \frac{3}{4}, \frac{1}{8}$	$\frac{1}{2}, \frac{3}{4}, \frac{3}{8}$			

Symmetry of special projections

Along $[001]$ $p4mm$
 $\mathbf{a}' = \frac{1}{2}\mathbf{a}$ $\mathbf{b}' = \frac{1}{2}\mathbf{b}$
Origin at $\frac{1}{4}, 0, z$

Along $[100]$ $c2mm$
 $\mathbf{a}' = \mathbf{b}$ $\mathbf{b}' = \mathbf{c}$
Origin at $x, \frac{1}{4}, \frac{1}{4}$

Along $[110]$ $c2mm$
 $\mathbf{a}' = \frac{1}{2}(-\mathbf{a} + \mathbf{b})$ $\mathbf{b}' = \frac{1}{2}\mathbf{c}$
Origin at $x, x + \frac{1}{4}, \frac{1}{8}$